



The Guttermaster Moulded No. 46 gutter is taken from the traditional cast iron No. 46 pattern to provide a strong, long lasting, yet lightweight and competitive gutter to give a decorative eaves detail on a wide range of applications. It can be used as a direct replacement for cast iron on refurbishment or on new build. Thick gauge extrusion, using a high strength alloy, 6063 T6, allows us to produce a much straighter gutter than other methods of manufacture (1.5mm/metre for extrusion compared with 3.5mm/metre for casting).

Standard Gutter Length

Use maximum length to minimise joints.

dim (mm)	Ref: MG/5x4	MG/6x4
W	125	150
T	2.2	2.2
D	100	100
L	TO 3000	TO 3000
dim (mm)	Ref: MG/8x6	
W	200	
T	2 to 3	
D	152	
L	TO 3000	

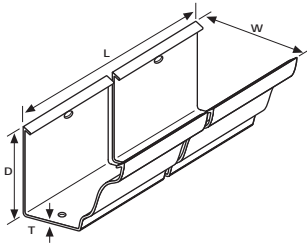

Fascia Brackets – with wind restraint

Other types of brackets available – please enquire.

dim (mm)	Ref: MFB/5x4	MFB/6x4
C	20	20
W	30	30
T	6	6
dim (mm)	Ref: MFB/8x6	
C	40	
W	35	
T	6	

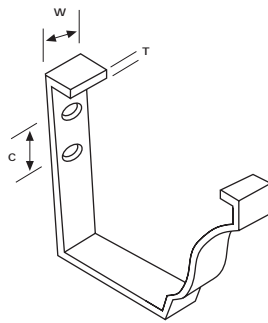

Rafter Brackets – with wind restraint

SIDE FIXING (MRS)

dim (mm)	Ref: MRS/5x4	MRS/6x4
L	100	100
C	100	100
W	30	30
T	6	6
dim (mm)	Ref: MRS/8x6	
L	100	
C	100	
W	35	
T	6	

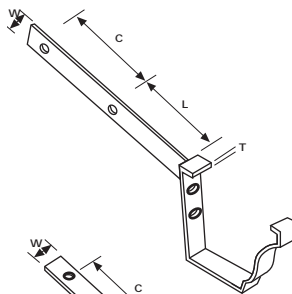

TOP FIXING (MRT)

dim (mm)	Ref: MRT/5x4	MRT/6x4
L	100	100
C	100	100
W	30	30
T	6	6
dim (mm)	Ref: MRT/8x6	
L	100	
C	100	
W	35	
T	6	

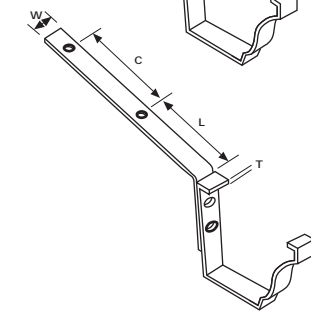

Please specify pitch of rafters/trusses.

Union Joints

dim (mm)	Ref: MUJ/5x4	MUJ/6x4
L	98	98
W	115	140
dim (mm)	Ref: MUJ/8x6	
L	98	
W	193	

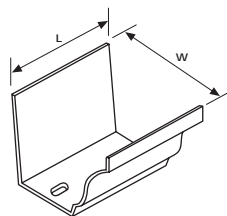

Rise & Fall Bracket

Due to the possible weight of water/snow that these gutters can carry, it is advisable to consult our Technical Department before considering this type of bracket.

Special Features:

- To prevent leakage, the lip detail at the top of the gutter section enables the joint to lock into place
- The vertical rear face of the gutter reduces unsightly gaps which can be particularly noticeable on polyester coated systems whilst allowing the gutter to be fixed to a fascia without brackets if required
- Exceeds British standard thickness requirements.
- To prevent wind uplift the Guttermaster system incorporates wind restraint lips which lock the gutter into position
- Extra large gutters available up to 400mm wide, 300mm deep

Running Outlets

Where deep fascia boards are to be used 'L1' can be increased. This should be noted when specifying.

dim (mm)	Ref: MRO/5x4	MRO/6x4
W (min)	69	81
L1	100	100
L2	300	300
dim (mm)	Ref: MRO/8x6	
W (min)	106	
L1	100	
L2	300	

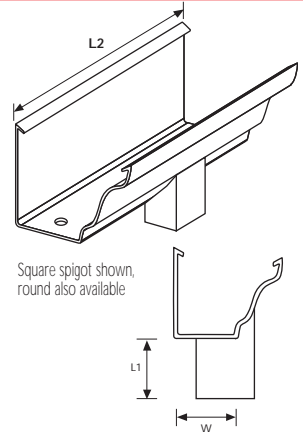

Angles

Where Ø is 90°

EXTERNAL ANGLE

dim (mm)	Ref: MEX90/5x4	MEX90/6x4
L	275	300
dim (mm)	Ref: MEX90/8x6	
L	350	

INTERNAL ANGLE

dim (mm)	Ref: MIN90/5x4	MIN90/6x4
L	275	300
dim (mm)	Ref: MIN90/8x6	
L	350	

Where Ø is 135°

EXTERNAL ANGLE

dim (mm)	Ref: MEX45/5x4	MEX45/6x4
L	202	212
dim (mm)	Ref: MEX45/8x6	
L	233	

INTERNAL ANGLE

dim (mm)	Ref: MIN45/5x4	MIN45/6x4
L	202	212
dim (mm)	Ref: MIN45/8x6	
L	233	

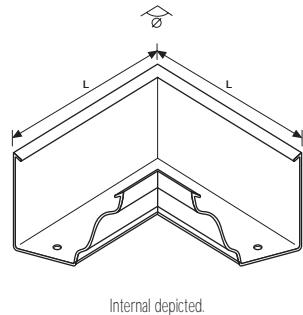

Angles are available in standard 90° & 135° (Ø). Non-standard angles are also readily available.

Stop Ends

LEFT HAND

dim (mm)	Ref: MSLH/5x4	MSLH/6x4
L	45	45
dim (mm)	Ref: MSLH/8x6	
L	45	

RIGHT HAND

dim (mm)	Ref: MSRH/5x4	MSRH/6x4
L	45	45
dim (mm)	Ref: MSRH/8x6	
L	45	

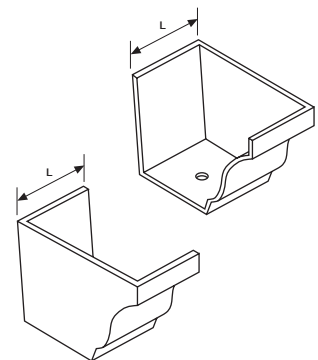

All dimensions can be adjusted to suit specific requirements.

DIMENSIONAL ABBREVIATIONS

W = Width	C = Centres	Ø = Angle
D = Depth	H = Height	T = Thickness
L = Length	A = Adjustability	P = Projection

N.B. The 200 x 150 Gutter is a pressing, and therefore does not have the lip feature.



DIRECT FIXING THE GUTTER WITHOUT BRACKETS (A)

Position the outlets to line up with drain location. Fix the outlets to the fascia board using the slots provided. Similarly, fix angles and stop ends. Set a line between the outlets and angles or stop ends and fix gutter lengths at maximum 500mm centres, again using the slots provided. Gutters should be secured to fascia board with No. 10 x 25mm zinc plated or stainless steel roundhead twin threaded screws.

FIXING WITH FASCIA BRACKETS (B)

Position the outlets to line up with drain location. Fix fascia brackets within 300mm either side of the outlets. Fix additional brackets within 150mm of angles and stopends. Set a line between these brackets, all remaining brackets should then be fixed at maximum 1,000mm centres. Brackets should be secured to fascia board with No. 10 x 30mm zinc plated or stainless steel countersunk twin threaded screws. The gutter is a 'Snap' fit under the wind restraints.

FIXING TO RAFTERS (C)

Position outlets as above. Bracket locations will be dictated by the rafter positions. For this reason it will be necessary to reduce the fixing centres to 600mm maximum. In practice this will usually mean that every rafter will have a bracket.

Rafter brackets should be secured using No.12 x 40mm. zinc plated or stainless steel countersunk twin threaded screws.

SEALING THE JOINTS (D)

Ensure both surfaces of the gutter joint are clean - Guttermaster recommends the use of Loctite 7063 Cleaner. Apply low modulus neutral cure silicone to BS5889 (type A) in 6mm diameter continuous beads around the full girth of the gutter. Set gutters 3mm apart (to allow thermal movement) and insert the union clip. Secure aluminium bolts using 29mm diameter neoprene backed washer and nuts (provided by Guttermaster). The spacers in the joint will offer resistance when the bolts are tight enough - DO NOT OVERTIGHTEN. Smear sealant around exposed threads of bolts. Remove excess sealant. Allow 24 hours for partial cure.

FURTHER INFORMATION CAN BE FOUND IN INSTRUCTION SHEET REF. IS-MG1, AVAILABLE ON REQUEST

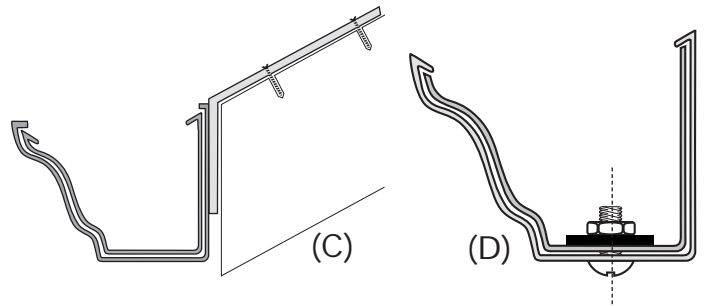
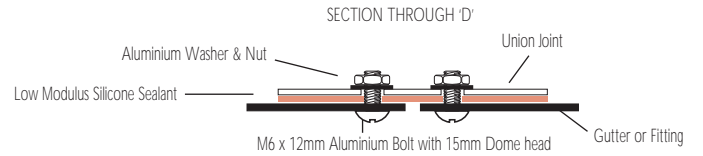
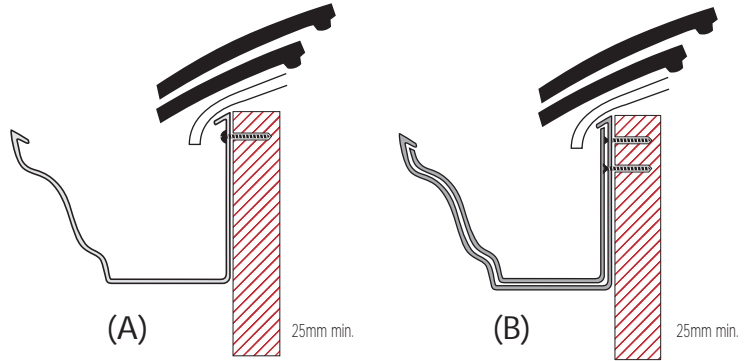

PURPOSE MADE COMPONENTS - PLEASE ENQUIRE.

