



In order to serve the requirements of all building types, two distinct forms of rainwater pipes have been produced.

On the following two pages you will find our traditional range, which covers the 'Iron look' designs with ornate collar joints favoured in period or character construction.

Page 14 features our 'Slimline Flush-Fix' anti-vandal product.

Standard Pipe Lengths with eared socket

SQUARE & RECTANGULAR:

dim (mm)	Ref: SQU/3x3	SQU/4x4	REC/4x3
W	76	100	100
W ₁	76	100	75
T	1.6	2.0	2.0
L	TO 6,000	TO 6,000	TO 6,000

CIRCULAR PIPE:

dim (mm)	Ref: DIA/63	DIA/75	DIA/100	DIA/150
W	63.5	76	102	150
T	1.6	1.6	1.6	2.5
L	TO 6,000	TO 6,000	TO 6,000	TO 6,000

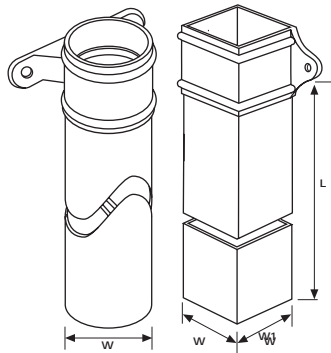

Offset/swan neck - 1-part

SQUARE & RECTANGULAR:

dim (mm)	Ref: SQOF/3x3	SQOF/4x4	REOF/4x3
L	100	100	100
P	TO 3000	TO 3000	TO 3000

CIRCULAR:

Ø°	Ref: DIOF/63	DIOF/75	DIOF/100
L	100	100	100
P	TO 3000	TO 3000	TO 3000

Ø°	Ref: DIOF/150
L	100
P	TO 3000

All standard offsets are constructed with 112.5° angles (θ). Offsets with non-standard bends are readily available.

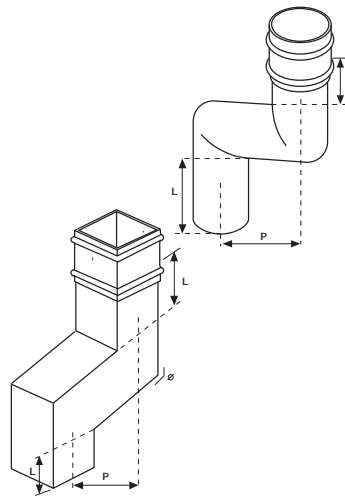

Offset/swan neck - 2-part adjustable

Suffix product code with 2P

Bend

SQUARE & RECTANGULAR:

dim (mm)	Ref: SQBE/3X3	SQBE/4X4	REBE/4X3
L	100	100	100

CIRCULAR:

dim (mm)	Ref: DIBE/63	DIBE/75	DIBE/100	DIBE/150
L	100	100	100	100

Circular, square and rectangular bends are available in standard 92.5°, 112.5° and 135° angles (θ), bends with non-standard angles are readily available.

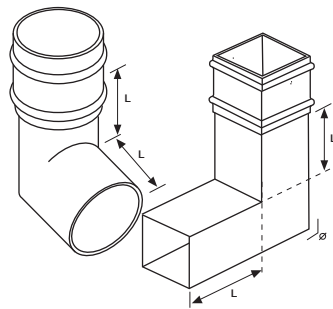

Shoes with eared socket

SQUARE & RECTANGULAR:

dim (mm)	Ref: SQSH/3x3	SQSH/4x4	RESH/4x3
L ₁	100	100	100
L ₂	40	40	40

CIRCULAR:

dim (mm)	Ref: DISH/63	DISH/75
L ₁	100	100
L ₂	40	40

dim (mm)	Ref: DISH/100	DISH/150
L ₁	100	100
L ₂	40	40

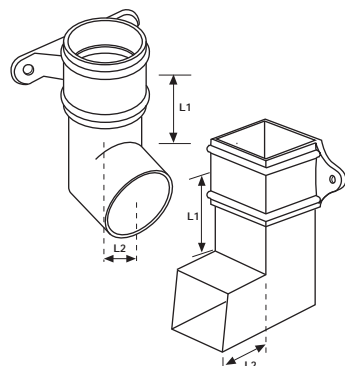

Special Features:

- Pronounced double ring on collars to faithfully reproduce the cast iron appearance
- Unusually long lengths of powder coated rainwater pipes can be supplied (up to 6m)
- Thickness up to 4mm readily available
- Square and round pipes available
- Unlike some competitive products, the Guttermaster socket joints do not exhibit excessive gaps requiring backing foam and copious amounts of sealant.

Saddle Clip

For use as intermediate fixing when using eared sockets.

SQUARE & RECTANGULAR:

dim (mm)	Ref: SQSC/3x3	SQSC/4x4	RESC/4x3
C	108	132	132
W	44	56	44

CIRCULAR:

dim (mm)	Ref: DISC/63	DISC/75
C	80	110
W	56	70

dim (mm)	Ref: DISC/100	DISC/150
C	110	168
W	91	116

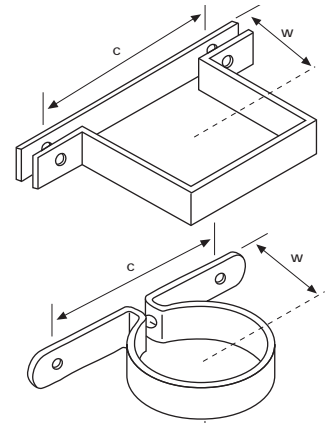

Branch

SQUARE & RECTANGULAR:

dim (mm)	Ref: SQBR/3X3	SQBR/4X4	REBR/4X3
L ₁	300	300	300
L ₂	150	150	150

CIRCULAR:

dim (mm)	Ref: DIBR/63	DIBR/75	DIBR/100	DIBR/150
L ₁	300	300	300	400
L ₂	150	150	150	150

Circular, square and rectangular branches are available in standard 92.5°, 112.5° and 135° angles (θ), branches with non-standard angles are readily available.

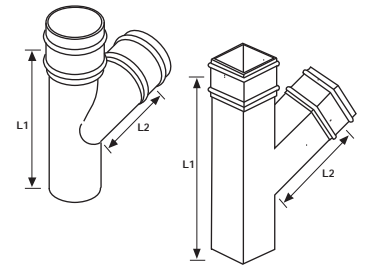

Small Base Clip

For use when pipe is positioned in narrow recesses.

SQUARE & RECTANGULAR:

dim (mm)	Ref: SQBC/3x3	SQBC/4x4	REBC/4x3
C	68	68	68
W	98	110	98

CIRCULAR:

dim (mm)	Ref: DIBC/63	DIBC/75
C	68	68
W	92	98

dim (mm)	Ref: DIBC/100	DIBC/150
C	68	68
W	111	136

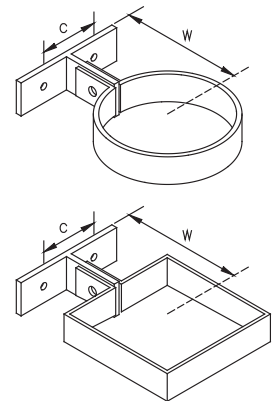

Extension Base Clip – Adjustable

For use when pipe requires fixing up to 250mm from structure.

SQUARE & RECTANGULAR:

dim (mm)	Ref: SQEB/3x3	SQEB/4x4	REEB/4x3
C	45	45	45
W (max)	288	300	288

CIRCULAR:

dim (mm)	Ref: DIEB/63	DIEB/75
C	45	45
W (max)	282	288

dim (mm)	Ref: DIEB/100	DIEB/150
C	45	45
W (max)	301	326

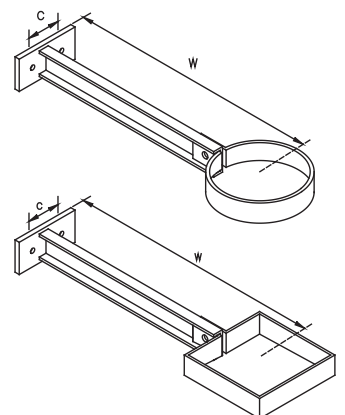



Access Pipe/Rodding Eye

SQUARE & RECTANGULAR:

dim (mm)	Ref: SQAP/3x3	SQAP/4x4	REAP/4x3
L	300	300	300
C	150	150	150
W	74	98	98

CIRCULAR:

dim (mm)	Ref: DIAP/63	DIAP/75
L	300	300
C	150	150
W	74	74

dim (mm)	Ref: DIAP/100	DIAP/150
L	300	300
C	150	150
W	98	98

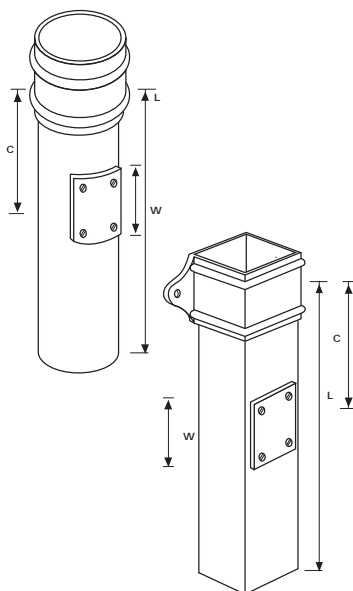

Hopper Heads

dim (mm)	Ref: SQHH/3x3	SQHH/4x4	REHH/4x3
W	257	257	257
D	179	179	179
H	175	175	175

dim (mm)	Ref: DIHH/63	DIHH/75	DIHH/100
W	257	257	257
D	179	179	179
H	175	175	175

Many other types of Hopper Heads are readily available – Please enquire.

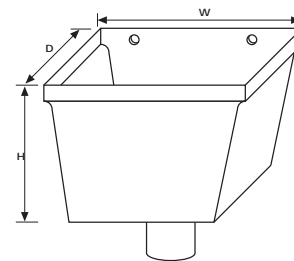

Iron Age Head

A distinctly ornate hopper head for use on period style buildings.

dim (mm)	Ref: SQIH/3x3	SQIH/4x4	REIH/4x3
W	415	415	415
D	186	186	186
H	183	183	183

dim (mm)	Ref: DIIH/63	DIIH/75	DIIH/100	DIIH/150
W	415	415	415	415
D	186	186	186	186
H	183	183	183	183

Motifs such as flowers or lions heads can be added to hopper head to individualise the building – please enquire.

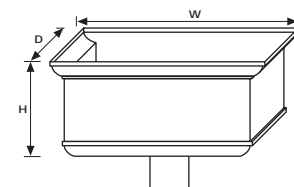

Adaptor (Various Types Available)

Can be used for transferring from dissimilar products such as UPVC, cast iron or earthenware.

Square and Rectangular: dim (mm)	Ref: SQAD/3x35	SQAD/4x4	READ/4x3	
Circular: dim (mm)	Ref: DIAD/63	DIAD/75	DIAD/100	DIAD/150

INSTALLATION

Ensure all pipes are set plumb. The distance from the wall will vary according to the type of fixing chosen.

Ensure there is sufficient room behind the pipe (see fig A) to 'Bed-in' your chosen gully/drain. If the foundations project beyond the line of the building it may be necessary to use a small offset (see fig B) or alternatively the extension base clip may be used to bring the whole stack away from the wall (see fig C).

FIXING USING CAST EARED SOCKETS (D)

Sockets should be fixed using No.12 x 50mm zinc plated or stainless steel twin threaded screws with washers, fixing into wall plugs. Alternatively, use 50x6mm zinc plated or stainless steel expanding sleeve anchors.

Fixings should be at not greater than 2,000mm centres. Saddle clips should be used as an intermediate fixing when required.

FIXING USING SMALL BASE CLIPS (E)

The 'T' base should be fixed to the wall using No.10 x 50mm zinc plated or stainless steel twin threaded screws with washers, fixing into wall plugs. The pipe clip is then bolted to the 'T' base using the M6x25mm stainless steel bolts, nuts and washers provided.

Fixings should be at not greater than 2,000mm centres.

FIXING USING EXTENSION BASE CLIPS (F)

The extension base should be fixed to the wall using No.10 x 50mm zinc plated or stainless steel twin threaded screws with washers, fixing into wall plugs. The extension piece is then cut down to give the desired stand-off using a hacksaw with suitable aluminium cutting blade, and the cut end de-burred. A 6mm hole should then be drilled in the extension piece using a suitable metal drill. The pipe clip is then bolted to the extension base using the M6x25mm stainless steel bolts, nuts and washers provided.

Fixings should be at not greater than 2,000mm centres.

SEALING THE JOINTS (G)

CIRCULAR: Each pipe and fitting is supplied with die cast socket (either with fixing ears or without).

Unlike other systems the top of the socket is not a loose fit to the pipe, so it is a matter of preference whether this is sealed

Lightly smear the end of each component with silicone. The socket is then lightly driven on to the pipe with a mallet. The pipe will locate into a recess within the socket.

SQUARE AND RECTANGULAR: Each component is supplied with the socket (either eared or uneared) welded on, unlike other systems the top of the socket is not a loose fit to the pipe, so it is a matter of preference whether this is sealed

Always ensure a 3mm gap is allowed for thermal movement (when using longer lengths of pipe allow 1.2mm/m).

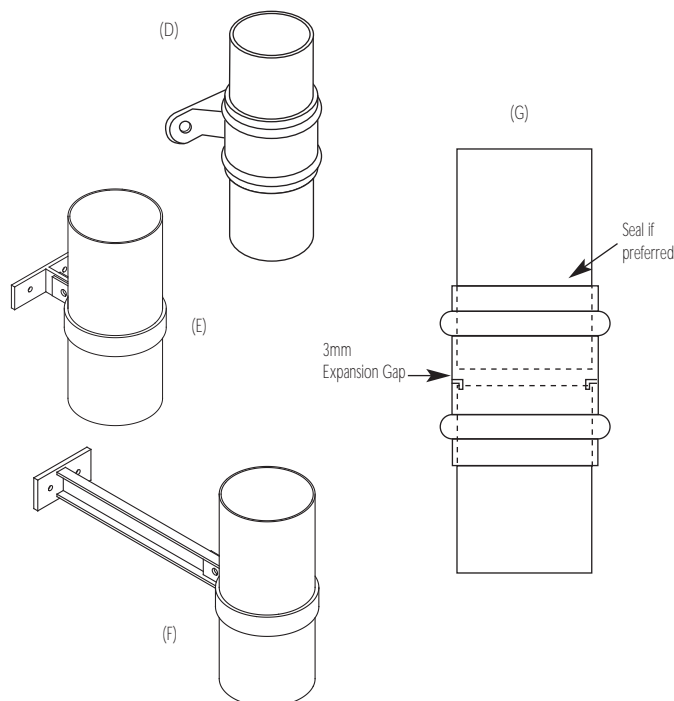
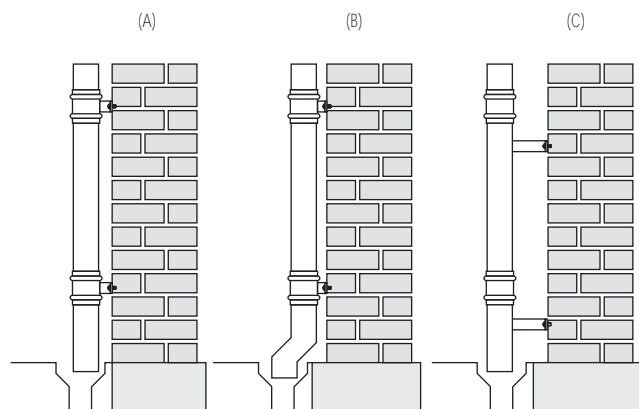

FURTHER INFORMATION CAN BE FOUND IN INSTRUCTION SHEET REF. IS-TP1, AVAILABLE ON REQUEST